



INNOVATION DURABILITY MODULARITY

Forecourt Solutions



McCowan Forecourt

Maximizing space, ensuring security and displaying products in an exterior or forecourt area can be challenging for C-Store & Gas Bar retailers.

We offer a wide range of attractive and durable forecourt products that maximize the use of space, are easy to maintain, are secure and provide easy access to merchandise and services.

Benefits include:

- Fabricated from high quality, UV and temperature resistant resin to prevent fading
- Doors are designed to prevent jamming caused by ice
- Units are designed to combat the effects of water and salt by using high quality stainless steel and satin-coated metal and finished with a durable powder coat
- Large removable liners and lids are constructed to minimize contact with the unit. Paper towels dispense easily
- Offered in a variety of colours and sizes

Solutions Built to Last

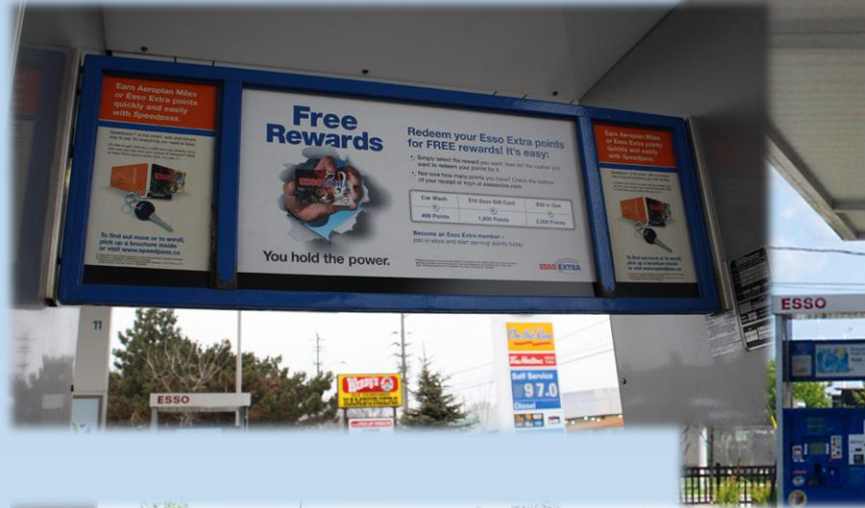

McCowan Forecourt MM-695 Double Sided Merchandiser

Features:

- Durable: manufactured from weather resistant materials
- Rust resistant stainless-steel base
- Ideal size for pump islands
- 2 pull-out plastic PVC security doors on both sides
- 2 padlocks and keys for security
- UV stabilizers used in plastic to eliminate fading
- Optional Top Sign for advertising
- Flat or cascading shelves available



Specifications:

Dimensions: 41"H x 56-½"W x 47"D

Shipping Weight: 250lbs

Standard Finish: Black / Grey

*Inquire for alternate finishes

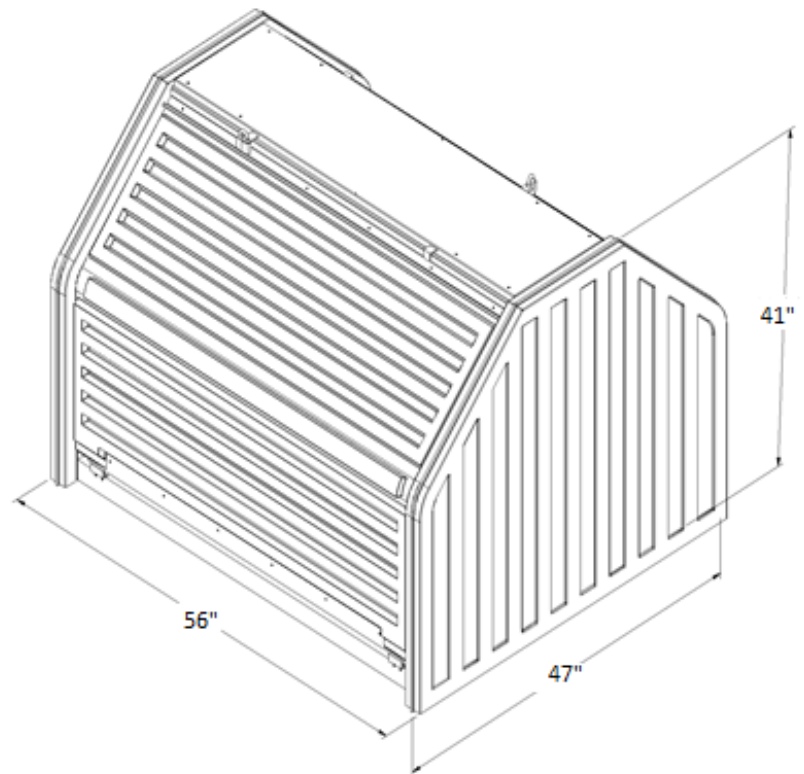

McCowan Forecourt

MM-696 Dual Sided Merchandiser with Roll-Up Doors

Features:

- **High security**
 - Easy roll up aluminum security doors designed to prevent jamming due to ice
 - Lockable T-Handle and keys
- Durable: manufactured from weather resistant materials
- Rust resistant stainless-steel base
- UV stabilizers used in plastic to eliminate fading
- Ideal design for pump islands
- Two adjustable shelves
- Optional Top Sign for advertising



Specifications:

Dimensions: 42"H x 50"W x 37"D

Shipping Weight: 250lbs

Standard Finish: Black / Grey

*Inquire for alternate finishes

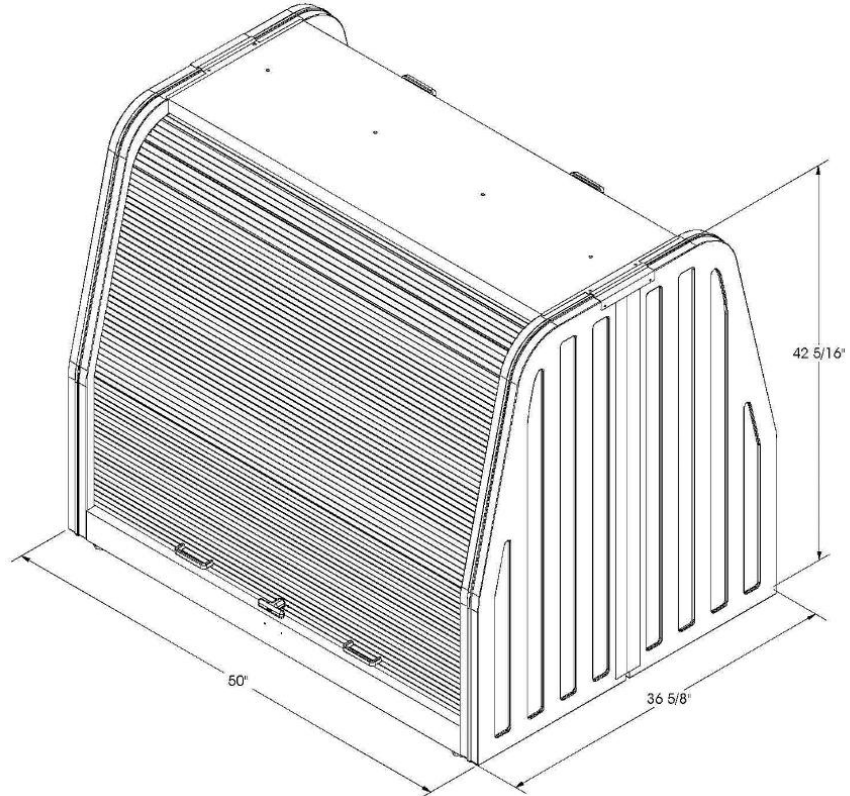

McCowan Forecourt MM-686 Slim Line Merchandiser

Features:

- **High security**
 - Easy roll up aluminum security doors designed to prevent jamming due to ice
 - Lockable T-Handle and keys
- Durable: manufactured weather resistant materials
- Rust resistant stainless-steel base
- UV stabilizers used in plastic to eliminate fading
- Thin profile ideal for store fronts or side walks
- Two adjustable shelves
- Optional Top Sign for advertising



Specifications:

Dimensions: 42"H x 50"W x 18- $\frac{1}{4}$ "D

Shipping Weight: 211lbs

Standard Finish: Black / Grey

*Inquire for alternate finishes

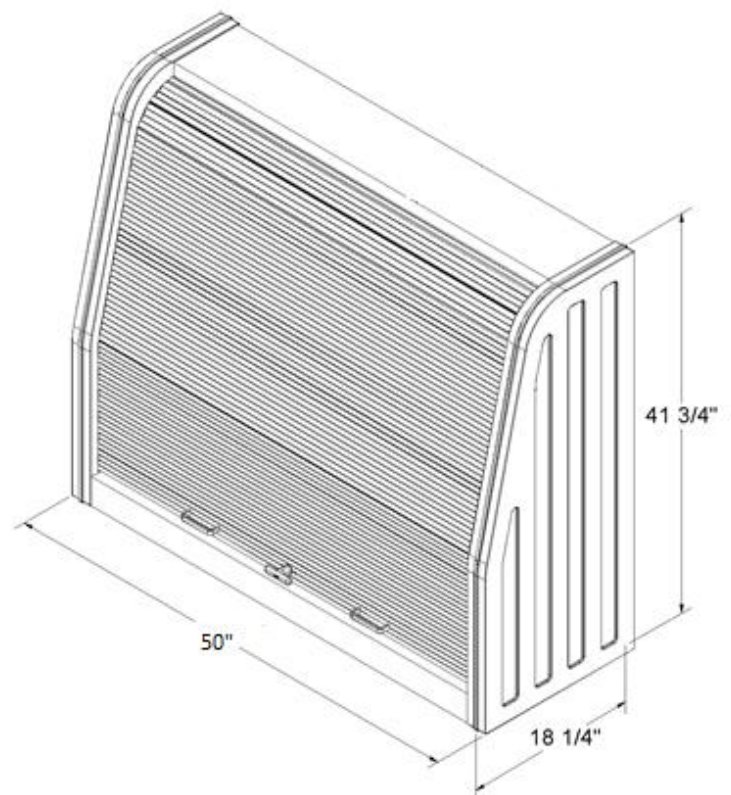

McCowan Forecourt MM-684 Merchandiser

Features:

- **High security**
 - Easy roll up aluminum security doors designed to prevent jamming due to ice
 - Lockable T-Handle and keys
- Durable: manufactured from weather resistant materials
- Rust resistant stainless-steel base
- UV stabilizers used in plastic to eliminate fading
- Thin profile ideal for store fronts or under the canopy
- Two stationary shelves
- Optional Top Sign for advertising



Specifications:

Dimensions: 46"H x 50"W x 26-3/8"D

Shipping Weight: 211lbs

Standard Finish: Black / Grey

*Inquire for alternate finishes

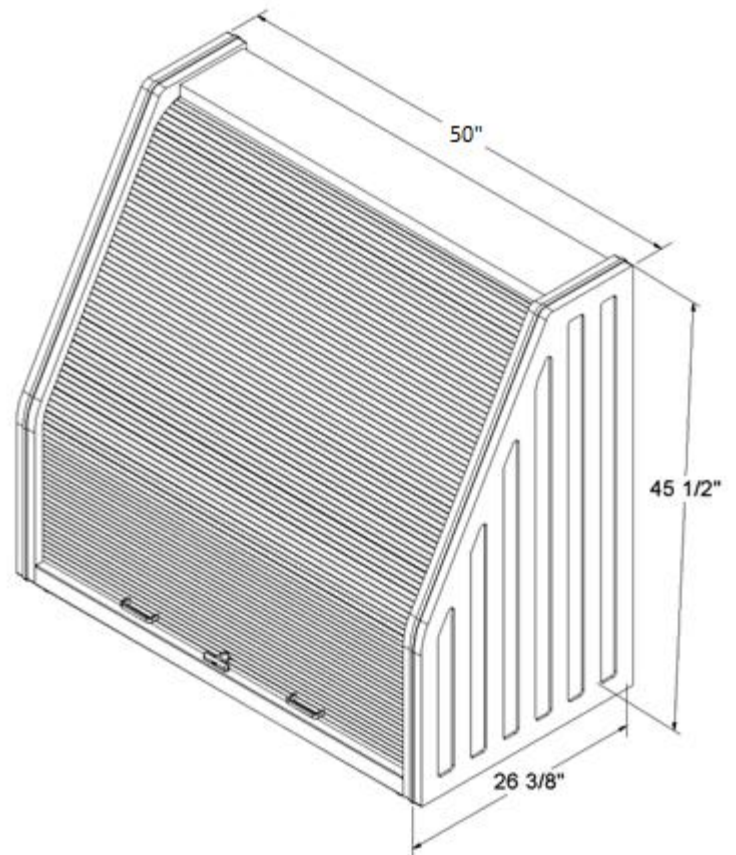

McCowan Forecourt MM-653 Tiered Skid Display



Features:

- High Capacity = 85 Bottles
- High quality rust resistant stainless-steel base
- 2x removable rust resistant shelves
- Aluminum advertising sign

Specifications:

Dimensions: 42"W x 29"D x 53"H (including sign, 8"H)

Standard Finish: Grey / Black

*Inquire for alternate finishes



McCowan Forecourt MM-655 Tiered Skid Display – Single Sided

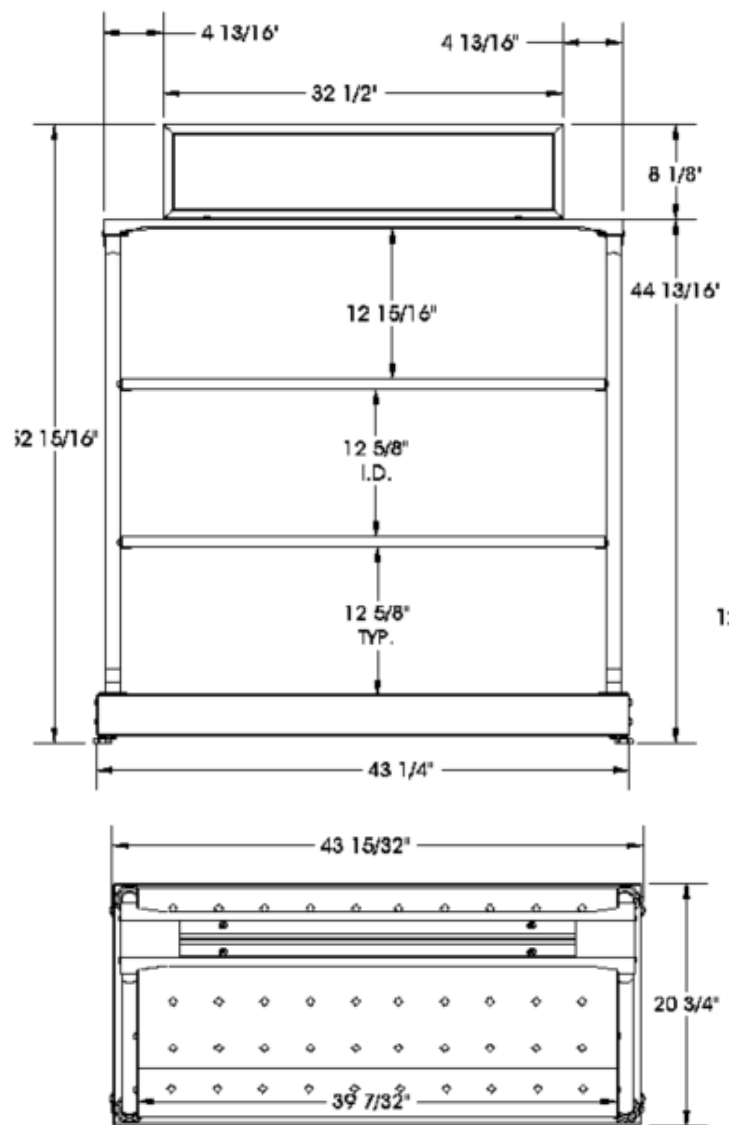

Features:

- High Capacity = 55 Bottles
- High quality rust resistant stainless-steel base
- 2x removable rust resistant shelves
- Aluminum advertising sign

Specifications:

Dimensions: 43.25"W x 20.75"D x 53"H (including sign, 8"H)

Standard Finish: Grey / Black

*Inquire for alternate finishes



McCowan Forecourt SD-SK-SEC : Wire Cage Lock-up

Features:

- High quality zinc coated steel
- Comes with 4 pad locks
- Predrilled holes in legs to secure to platform or concrete
- Can be used to display firewood or salt

Specifications:

Dimensions: 42 3/8"W x 44"D x 30"H

Standard Finish: Grey, Black

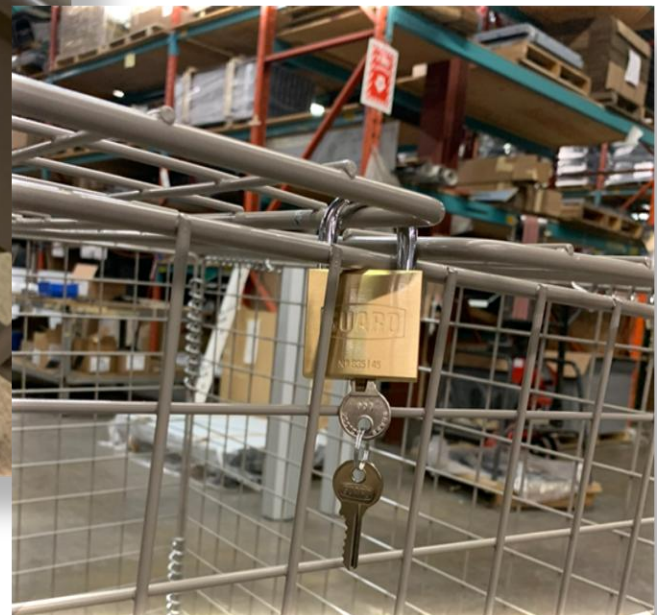

McCowan Forecourt MM-EXT-TOP Merchandiser Sign



Features:

- Durable: manufactured from weather resistant materials
- Easy to insert sign holder
- Heavy duty weather resistant easy peel tape secures sign to merchandiser
- Fits on MM-684/685/686/695/653/ 655 merchandisers
- Ideal for product pricing and advertising promotions

Specifications:

Dimensions: 8.5"H x 32.5"W x 3"D

Standard Finish: painted to match merchandiser ordered

Shipping Weight: 5 lbs.



McCowan Forecourt MU-714 Washer Fluid Jug Recycle Pole

Features:

- **Highly Visible** - Bright colour and recycle logo ensure customer awareness
- **User Friendly** - Pole removes easily from base to recycle empty jugs
- **Eliminate Waste Overflow** - Keeps waste containers free of large fluid jugs
- **Durable & Stable Design** - High quality polyethylene base weighs 30lbs for wind protection
- **Eco-Friendly Site Upgrades** - Encourage eco responsible actions by consumers and operators

Specifications:

Dimensions: 12.5"W x 9"D x 62"H

Shipping Weight: 30lbs

Standard Finish: Green or Blue



McCowan Forecourt MU-717 Double Sided Waste Windshield Unit

Features:

- Manufactured from durable, weather resistant materials
- Roto-molded from high density polyurethane with UV stabilizers to eliminate fading
- Resists staining from oils & chemical liquids
- Provides easy access from either side of the pump
- Extra large waste receptacle with swinging stainless steel cover
- Removable lid for easy removal of garbage bags and replacement of paper towels
- Removable liner for easy cleaning
- Fits industrial size poly garbage bags 35"x 50"
- Dual sided high-capacity washer buckets
- Includes 2x squeegees, 2x paper towel holders, 1x removable trash liner



Specifications:

Dimensions: 46H x 24 ½"W x 30"D

Shipping Weight: 88lbs

Standard Finish: Black / Grey

*Inquire for alternate finishes



McCowan Forecourt MU-710 Single Sided Waste Windshield Unit

Features:

- Manufactured from durable, weather resistant materials
- Roto-molded from high density polyurethane with UV stabilizers to eliminate fading
- Resists staining from oils & chemical liquids
- Extra large waste receptacle with swinging stainless steel cover
- Removable lid for easy removal of garbage bags and replacement of paper towels
- Removable liner for easy cleaning
- Fits industrial size poly garbage bags 35"x 50"
- Single sided high-capacity washer buckets
- Includes 1x squeegee, 1x paper towel holder, 1x removable trash liner



Specifications:

Dimensions: 46"H x 23½"W x 24"D

Shipping Weight: 88lbs

Standard Finish: Black / Grey / Blue

*Inquire for alternate finishes



McCowan Forecourt MU-712 Waste Container

Features:

- For use under canopy Heavy Duty durable & stable design
- Weather resistant design keeps water out , ideal for open or covered environments
- Fade resistant material
- User friendly easy-lift lid with foot-step
- Fits standard trash bags
- Optional Ashtray attachment available

Specifications:

Dimensions: 39.25"H x 19.5"W x 15.5" D

Shipping Weight: 20lbs

Standard Finish: Black , Grey & Blue

*Inquire for alternate finishes



McCowan Forecourt MU-715 Fuel Spill Kit

Features:

- Heavy duty durable and stable design
- Unit holds absorbent materials to clean spills
 - 25L bag of absorbent
 - 1 absorbent sock
 - 1 scoop
- Heavy duty durable and stable design
- Weather resistant design keeps water out , ideal for open or covered environments
- Fade resistant material will not rust
- French & English decal available
- User friendly easy-lift lid with foot-step

Specifications:

Dimensions: 28"H x 19"W x 16½"D

Shipping Weight: 15lbs

Standard Finish: Black , Grey & Blue

*Inquire for alternate finishes



McCowan Forecourt MU-703 Windshield Service Centre

Features:

- Manufactured from durable, weather resistant materials
- Roto-molded from high density polyurethane with UV stabilizers to eliminate fading
- Resists staining from oils & chemical liquids
- Unit comes with mounting brackets
- Extra large washer fluid bucket
- Paper towel holder & dispenser included

Specifications:

Dimensions: 36"H x 15½"W x 11½"D

Shipping Weight: 15lbs

Standard Finish: Black and grey

*Inquire for alternate finishes

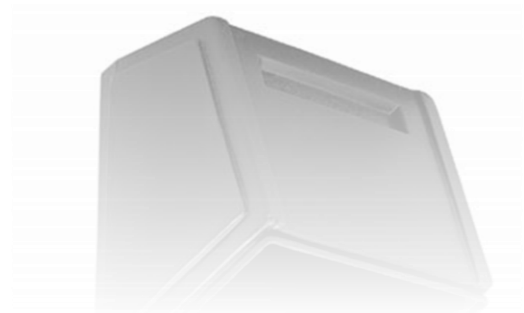

Contact Information

McCowan Design & Manufacturing are experts in design, manufacturing and distribution of complete store fixture solutions for C-Store, Gas Bar, Pharmacy, Food Service & other Specialty Retailers.

Serving independent retailers and national chains, McCowan's unique modular systems combined with our in-house design and modern production facilities, allow us to create custom store fixture solutions with unrivaled delivery.

www.mccowan.ca

sales@mccowan.ca

888-782-5189

Corporate Headquarters :
McCowan Design & Manufacturing
1760 Birchmount Road,
Toronto, Ontario
M1P 2H7

